

Part number

CHPW 48 LS



Surface mounting housing, W-TYPE series, with 1 lever, Pg36 cable entry, size "104.62", with metal cover

Product description

Product type	Surface mounting housing
Series	W-TYPE
Closing type	With 1 lever
Size	Size 104.62
Cable entry	With cable entry Pg36
Specification	With metal cover

Technical data

IP degree of protection	IP65
--------------------------------	------

Further technical details

Weight	1.182,00 g
Operating temperature range (min, max)	-40°C...+125°C

Material properties

Other materials	Lever: Stainless steel, polyamide (PA)
Colour	RAL 9005 black
RoHs conformity	Compliant
China RoHs - EFUP	E
REACH SVHC substances	No

Approvals / Standards

Certifications	DNV, BV
UL	ECBT2
cUL	ECBT8

General ordering information

EAN13 code	8015747024044
-------------------	---------------

Packaging Information

Packaging length	305,00 mm
Packaging height	180,00 mm
Packaging width	275,00 mm
Packaging weight	4,93 kg
Packaging volume	15,10 dm ³
Packaging description	Carton box
Packaging quantity	4 Pcs
Packaging EAN code	8015747024051
Sub-packaging weight	1,23 kg
Sub-packaging description	Plastic packaging
Sub-packaging quantity	1 Pcs
Sub-packaging EAN barcode	8015747024068

Part number

CHPW 48 LS



Catalogue drawings

CHIW LS

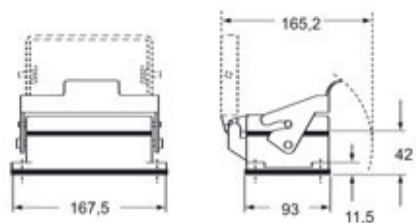

CHPW LS MHPW LS

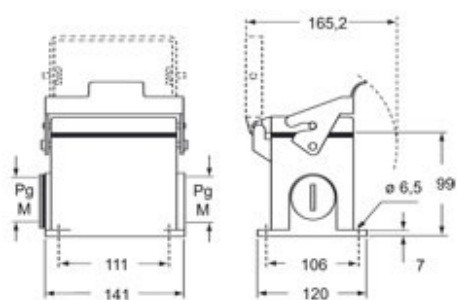

Notes

Dimensions shown in mm are not binding and may be changed without notice.